

2024

TITANS OF METAL FEST

BRAND IDENTITY

TOMF
x x x x
TITANS OF METAL FEST

TITANSOFMETAL.COM

Intro

The purpose of this manual is to standardize the festival's image across all applications, in order to facilitate its identification, acceptance, and the achievement of a consistent and permanent visual unity. This document is intended to serve as a guide and act as a catalyst for new creative possibilities, with clear communication objectives and a solid projection of the brand.

Iván Jahzeel

Iván Jahzeel Villavicencio Orrico
CTO Medussa Entertainment

TITANSOFMETAL.COM

Index

01

Introduction

Permanent visual unity.

02

Logotype

Downloadables and specs.

03

Color

RGBs and Pantone

04

Typography

Fonts used in several application case studies

05

Applications

You can describe the topic of the section here

06

Stationary

You can describe the topic of the section here

01

Introduction

Purpose, permanent visual unity.



TOMF

TITANS OF METAL FEST

The main logo features the letters 'TOMF' in a large, white, brush-stroke style. The 'T' is shaped like a dragon's head with wings. Small white birds are scattered around the letters. Below 'TOMF' is the text 'TITANS OF METAL FEST' in a pink, outlined, graffiti-style font.



T.O.M.F.

TITANS OF METAL FEST

About the brand logo

The ToM® logo represents the power and majesty of the gods of metal music. By combining visual elements that allude to Art Deco and the stone monuments of Mexico City, the logo symbolizes an indomitable force, rebellion, and the unity of the metal community.

The stylized letters and magenta tones enhance the raw energy and intensity of the genre, evoking a sense of power and respect for the metal legends that dominate the stage.

TITANSOFMETAL.COM



TOMF

TITANS OF METAL FEST

In the vast expanse of the cosmos, four titanic deities arose from the primordial energies that shaped the universe, each a different force, reverberating through the void like the raw power of metal. Born from the very fabric of dark stars, these titans were destined to face their internal hell and maintain the cosmic balance through their primal, thunderous power.

TITANSOFMETAL.COM



MAGNUS TITANUS

Magnus Titanus, the mightiest of them all, was forged in the celestial fires of *Ignis Immortalem*. His existence was a symphony of power, like the thundering beats of a double bass drum. With the strength to move mountains and the wisdom of the ancients, he constantly fought the temptation to succumb to the intoxicating allure of power and corruption. His eyes, burning like twin suns, were mirrors of his eternal struggle between righteousness and the tantalizing darkness that sang to him like a guitar.



ASTRA CELESTIA

Astra Celestia, a titaness of ethereal beauty, emerged from *Aetherius Caelum*, the endless skies of the heavens. Her essence was like the haunting wail of a metal ballad, capable of stirring love and harmony but also provoking hatred and fury. She longed to create peace, but the chaotic storm of emotions she unleashed resonated like a discordant chord. Her silver hair flowed like a river of stars, each strand a conduit of cosmic energy, both creative and destructive, much like the soaring highs and crushing lows of a metal opera.



THUNDERCLAW STARSABLE

Thunderclaw Starsable, a magnificent lion with a humanized form, was born from *Fulgur Naturalis*, the raw force of nature and feline forces. His existence was a brutal clash of primal instincts and higher reasoning, like a breakdown in a metal song. His roar could shatter mountains and stir tsunamis, while his wisdom could calm the fiercest storm. Torn between his beastly nature and his human conscience, Thunderclaw's journey was a quest for balance, like the pulse of a pounding drum beat.

CYBER IRONSTRIKE

Cyber Ironstrike, a cyborg of cosmic metal and circuits, was created in the heart of *Machina Ultima*, the forge of the gods. His infinite artificial intelligence was akin to a complex metal composition, capable of creating worlds of beauty or destroying them in an instant. Cyber's struggle was in understanding the concept of humanity and the moral choices that guided it, much like a metal guitarist finding the perfect balance between shredding speed and soulful melody. Despite his mechanical nature, he sought the meaning of emotions and the weight of every choice, caught between the cold logic of a machine and the raw emotion of a wailing guitar solo.

Main logotype

Logotype

Winged ornament elements in main typography separated by winged x's as points. White shadow on lower line MATTERS.

Negative

In this application, main letters do not possess any shadows. Previous white shadow for lower line becomes dark.

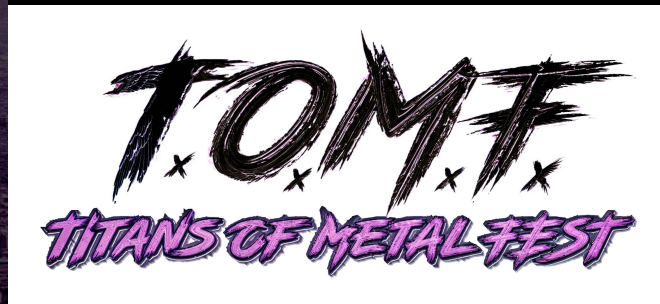

Logo construction

Size

Proportions for aspect ratio

Color

White main / magenta lower

Typography

Road Rage Regular

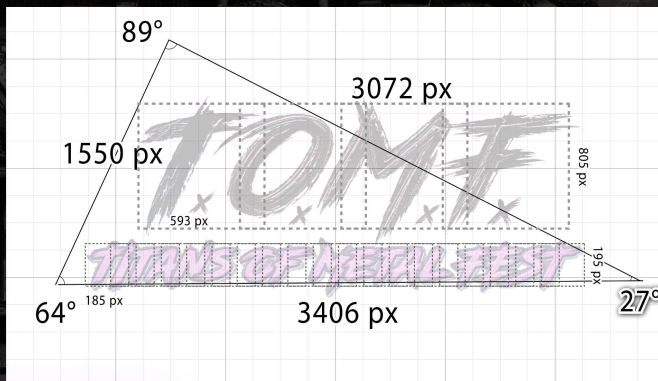
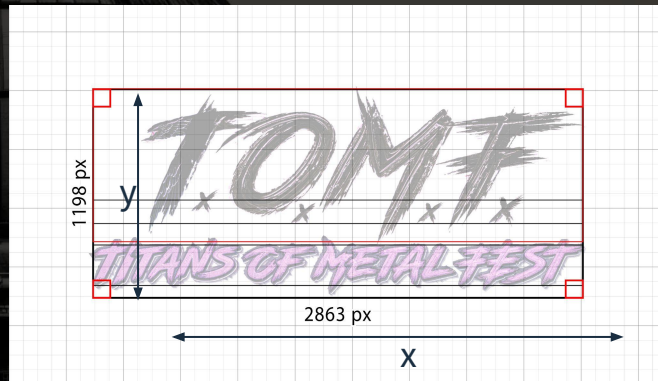

03

Brand color

RGBs & Pantone

Palette brand colors

Primary

Magenta for titles and call-outs

Accent

For links, clickables, and visual appeal

Texts

Regular data

Alternatives

Backgrounds

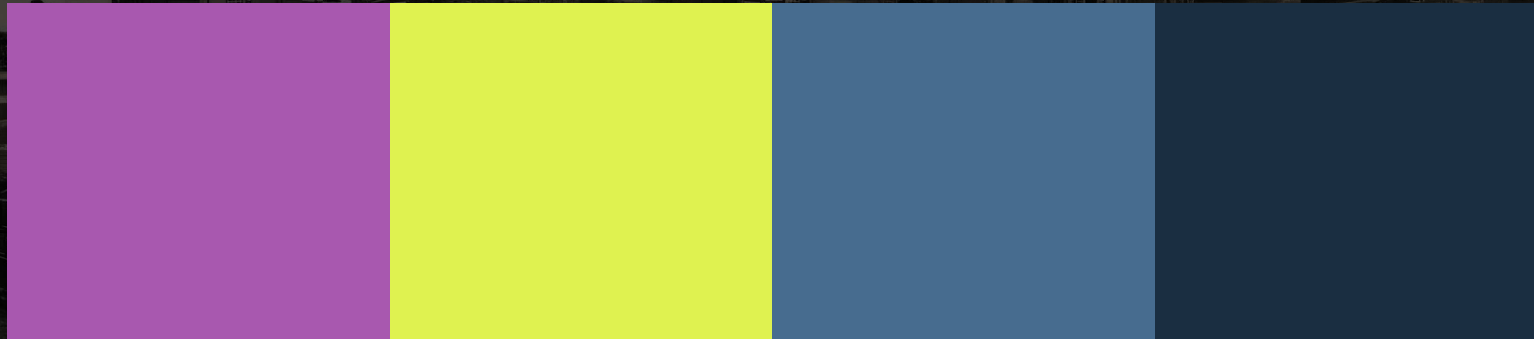

04

Typography

3 Fonts used for identity, different purposes

Typography

Fonts used for identity

ROAD RAGE

ABCDEFGHIJKLMNOPQRSTUVWXYZ

ABCDEFGHIJKLMNOPQRSTUVWXYZ

1234567890.,:;?!

ROCKSTAR

ABCDEFGHIJKLMNOPQRSTUVWXYZ

ABCDEFGHIJKLMNOPQRSTUVWXYZ

1234567890.,:;?!

League Gothic

ABCDEFGHIJKLMNOPQRSTUVWXYZ

abcdefghijklmnopqrstuvwxyz

1234567890.,:;?!

[DOWNLOAD HERE](#)

IDENTITY GUIDELINES KIT

T.O.M.F.
TITANS OF METAL FEST

2025



TITANSOFMETAL.COM



T.O.M.F.
TITANS OF METAL FEST

W.A.S.P.

GRAVELER **AZZI BORDEN** **h.h.'s Priest**

MONSIEUR WASP **FEAR FACTORY** **ILLUMINATES** **Six Feet Under** **WASTELAND**

1 MARZO, 2024
TITANSOFMETAL.COM

Parque Bicentenario MEDUSA

T.O.M.F.
TITANS OF METAL FEST

W.A.S.P.

GRAVELER **AZZI BORDEN** **h.h.'s Priest**

MONSIEUR WASP **FEAR FACTORY** **ILLUMINATES** **Six Feet Under** **WASTELAND**

1 MARZO, 2024
TITANSOFMETAL.COM

Parque Bicentenario MEDUSA

T.O.M.F.

TITANS OF METAL FEST



WASP

General Wesley

Lizz Borden

Kik's Priest

Municipal Waste

Fear Factory

Lullabies

Six Feet Under

S.O.B.

1 MARZO, 2024

TITANSOFMETAL.COM

Parque Bicentenario

MEDUSA ENTERTAINMENT

Help/Support/Questions

ivan@titansofmetal.com

+51 1 55 1800 9748

titansofmetal.com

DOWNLOAD ELEMENTS

Visit titansofmetal.com

MEDUSSA ENTERTAINMENT

This presentation contains dynamic Google Drive URL's. For any updates, please feel free to find the original document: [HERE](#)



[Facebook](#)



[Instagram](#)